

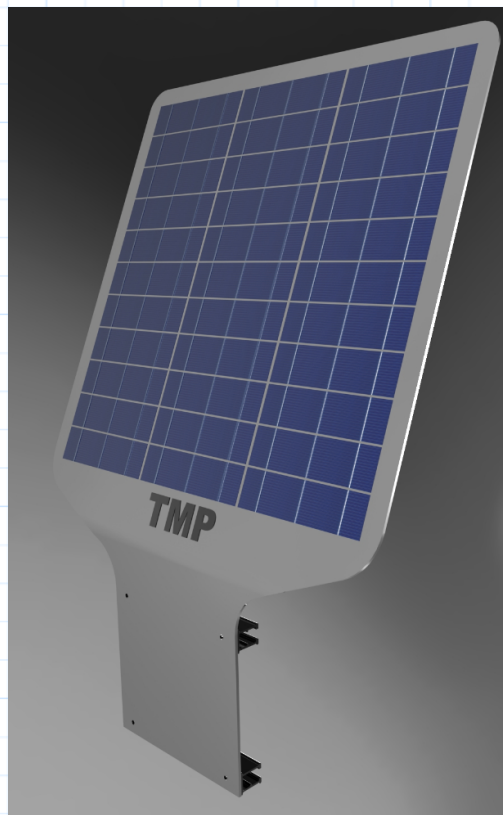

1.0 Introduction

A solar cell assembly is to be mounted to a street sign. This solar cell assembly comprises of a profiled aluminium plate as the body of the assembly along with a tubular steel stiffener. This assembly is mounted to its supporting pole via a rivetted connection.



This structure will be exposed to the environment and as such will be exposed to wind loads. The purpose of this investigation will be to ascertain the wind loads the structure will be exposed to, and calculate the stresses that the wind load will impart into the structure and mounting rivets.

1.1 Scope of report

The scope of this report is limited to the following areas:

1. Using the relevant standards, determine a wind load case for the structure.
2. Determining the stresses in the joint between the 'body' and the support, (currently a riveted joint).
3. Determining the stresses in the 'body' of the structure.

1.3 Reference document

Ref 1:- BS EN 12899-1, Table NA 2

Ref 2:- 5.3 of EN1991-1-4

Ref 3:- Sign Structures Guide, Support Design for Permanent UK Traffic Signs to BS EN12899-1:2007 and structural Eurocodes, September 2010, Section 3.15

Ref 4:- Sign Structures Guide, Support Design for Permanent UK Traffic Signs to BS EN12899-1:2007 and structural Eurocodes, September 2010, Section 3.3

Ref 5:- BS EN 12899-1, Table 7

Ref 6:- Fundamentals of Machine Component Design, 10.10 Pg 436

Ref 7:- Solar Capture doc 985-001 Module Plate

2.0 Sign geometry, Ref 7

Sign height

$$l := 758 \text{ mm}$$

Sign width

$$b := 520 \text{ mm}$$

Sign weight

$$W_{sign} := 3.95 \text{ kg}$$

Sign force due to gravity

$$M_g := W_{sign} \cdot g = 38.736 \text{ N}$$

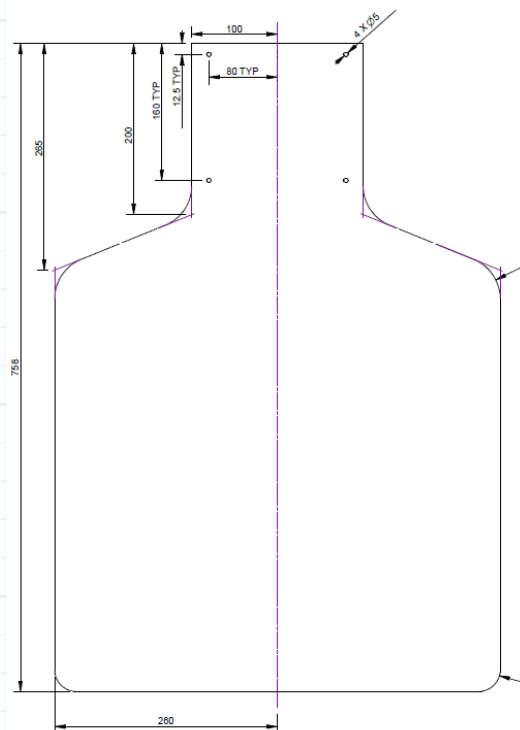



2.1 Wind load for installation.

Assumptions:

The sign may be installed anywhere in the UK, including coastal areas.

Maximum installation height

$$H := 4 \text{ m}$$

Basic Wind Pressure, Ref 1

$$w_b := 2 \frac{\text{kN}}{\text{m}^2}$$

2.2 Force Coefficient.

Aspect ratio of sign

$$\lambda := \frac{l}{b}$$

$$\lambda = 1.458$$

Therefore from, Ref 1

$$c_f := 1.3$$

2.3 Total wind force.

Total area of sign, from CAD

$$A_{ref} := 319333.8 \text{ mm}^2$$

From Ref 3, $c_s c_d$ for signs can be taken as 1

$$c_s c_d := 1$$

From Ref 2, Total wind force is

$$F_w := c_s c_d \cdot c_f \cdot w_b \cdot A_{ref}$$

$$F_w = 0.83 \text{ kN}$$

2.4 Partial Safety Factors

Wind, dynamic, snow and point loads, Ref 1

$$Y_{f1} := 1.35$$

Dead load, Ref 1

$$Y_{f2} := 1.2$$

Additional factor Ref 4

$$Y_{f3} := 1.2$$

2.5 Design Load cases.

Design load case from wind

$$F_{wd1} := F_w \cdot Y_{f1} \cdot Y_{f3}$$

$$F_{wd1} = 1.345 \text{ kN}$$

Design load case from self weight

$$F_{wd2} := M_g \cdot Y_{f2} \cdot Y_{f3}$$

$$F_{wd2} = 0.056 \text{ kN}$$

3.1 Ascertaining load in the rivets connecting the sign body to the supporting struture.

3.1.1 Wind load from the rear of the sign.

The sign is fastened to its support bracketry via a series of six pop rivets. These rivets are arranged as shown in the following figure.

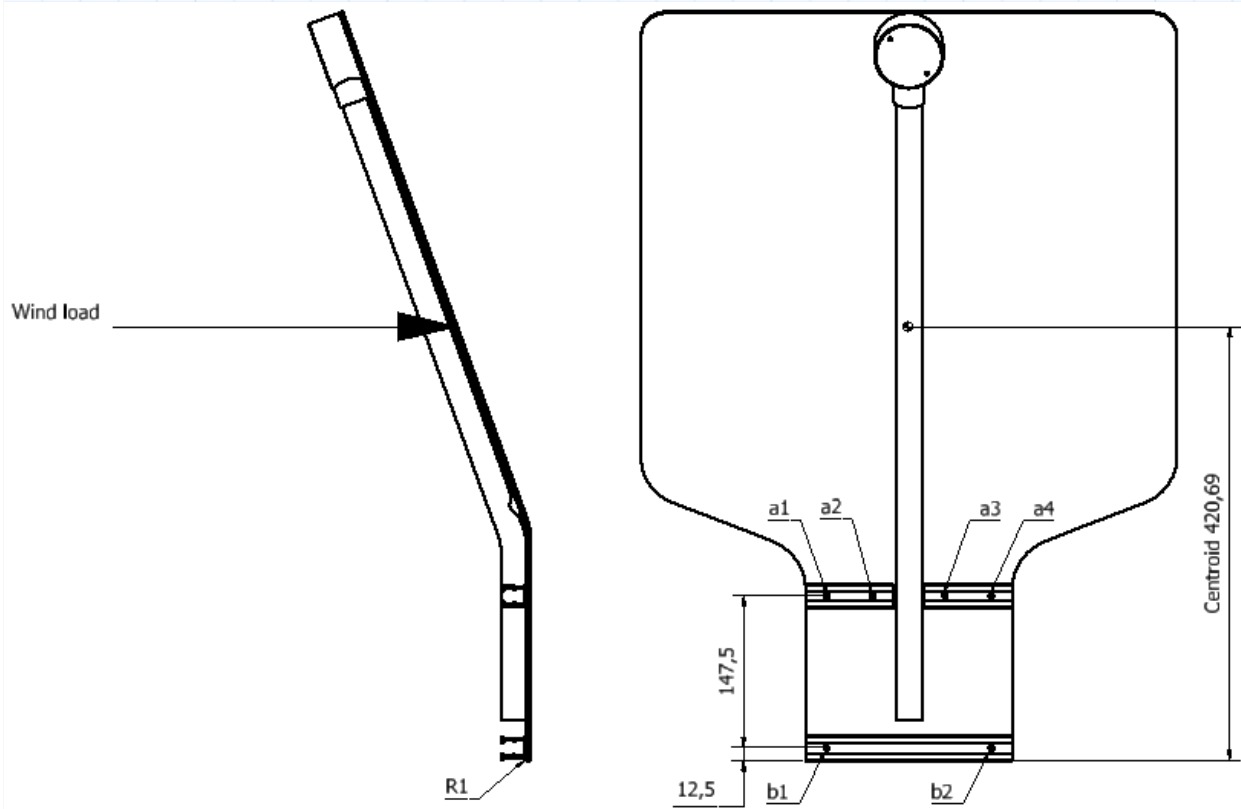

It is assumed that the wind loading is applied at the the centroid of the stucture. From this arrangement the loading and hence stresses in the rivets can be determined, assuming:

1. The wind load attempts to rotate the sign about point R1.
2. All deflections of the sign due to wind load are ignored. This will give a conservative result as some of the wind load will go into deflecting the sign and hence reduce the stress in the rivets.

Ref 6

Design load case from wind loading

$$F_{wd1} = 1.345 \text{ kN}$$

Load application distance

$$d_{F_{wd1}} := 420.69 \text{ mm}$$

Moment applied about R1

$$M_{R1} := F_{wd1} \cdot d_{F_{wd1}}$$

$$M_{R1} = 565.842 \text{ N} \cdot \text{m}$$



Distance of rivet a1, a2, a3 and a4 from rotation point

$$d_{a1234} := 160 \text{ mm}$$

Distance of rivet b1 and b2 from rotation point

$$d_{b12} := 12.5 \text{ mm}$$

Number of rivets in row a

$$n_a := 4$$

Number of rivets in row b

$$n_b := 2$$

Forces expressed in terms of distance from rotation point

$$F_{a1234} := \frac{d_{b12}}{\left(\frac{d_{a1234}}{d_{b12}} \right)}$$

$$F_{a1234} = 0.977 \text{ mm}$$

$$F_{a12} := \frac{d_{a1234}}{\left(\frac{d_{a1234}}{d_{a1234}} \right)}$$

$$F_{a12} = 160 \text{ mm}$$

Total forces expressed in terms of distance from rotation point

$$F_a \text{ total} := (F_{a1234} \cdot n_b) + (F_{a12} \cdot n_a) \quad F_a \text{ total} = 641.953 \text{ mm}$$

Maximum force applied to rivet

$$F_{max_rear} := \frac{M_{R1}}{F_a \text{ total}}$$

$$F_{max_rear} = 881.439 \text{ N}$$

3.1.2 Wind load from the front of the sign.

Again the sign is fastened to its support bracketry via a series of six pop rivets. These rivets are arranged as shown in the following figure.

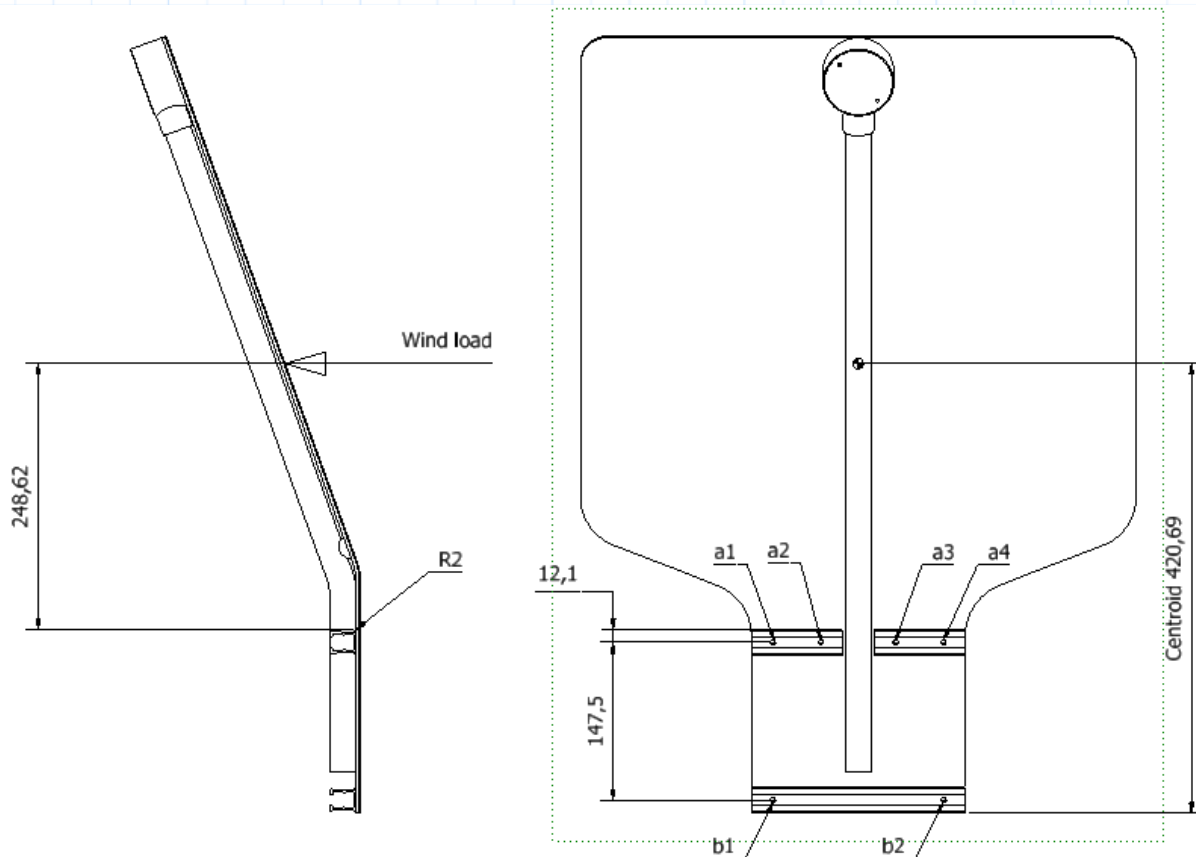

It is assumed that the wind loading is applied at the the centroid of the stucture. From this arrangement the loading and hence stresses in the rivets can be determined, assuming:

1. The wind load attempts to rotate the sign about point R2.
2. All deflections of the sign due to wind load are ignored. This will give a conservative result as some of the wind load will go into deflecting the sign and hence reduce the stress in the rivets.

Ref 6

Design load case from wind loading

$$F_{wd1} = 1.345 \text{ kN}$$

Load application distance

$$d_{Fwd2} := 248.62 \text{ mm}$$

Moment applied about R2

$$M_{R2} := F_{wd1} \cdot d_{Fwd2}$$

$$M_{R2} = 334.402 \text{ N} \cdot \text{m}$$



Distance of rivet a1, a2, a3 and a4 from rotation point

$$d_{a1234} := 12.1 \text{ mm}$$

Distance of rivet b1 and b2 from rotation point

$$d_{b12} := 159.6 \text{ mm}$$

Number of rivets in row a

$$n_a := 4$$

Number of rivets in row b

$$n_b := 2$$

Forces expressed in terms of distance from rotation point

$$F_{a1234} := \frac{d_{b12}}{\left(\frac{d_{a1234}}{d_{b12}} \right)}$$

$$F_{a1234} = 2105 \text{ mm}$$

$$F_{a12} := \frac{d_{a1234}}{\left(\frac{d_{a1234}}{d_{a1234}} \right)}$$

$$F_{a12} = 12.1 \text{ mm}$$

Total forces expressed in terms of distance from rotation point

$$F_a \text{ total} := (F_{a1234} \cdot n_b) + (F_{a12} \cdot n_a)$$

$$F_a \text{ total} = 4258.674 \text{ mm}$$

Maximum force applied to rivet

$$F_{max_front} := \frac{M_{R2}}{F_a \text{ total}}$$

$$F_{max_front} = 78.523 \text{ N}$$

3.2 Maximum stress in the rivets

From the previous calculation it can be seen that the maximum load on the rivets occurs when the wind load is from the rear of the structure, i.e

$$F_{max_rear} = 881.439 \text{ N}$$

This value was used to determine the maximum stress in the rivets.

To determine the stress in the rivet the diameter of the rivet body and the rivet mandrel need to be known. For the purpose of the following calculation it is assumed that there is no residual preload applied to the rivet after the forming process has been performed.

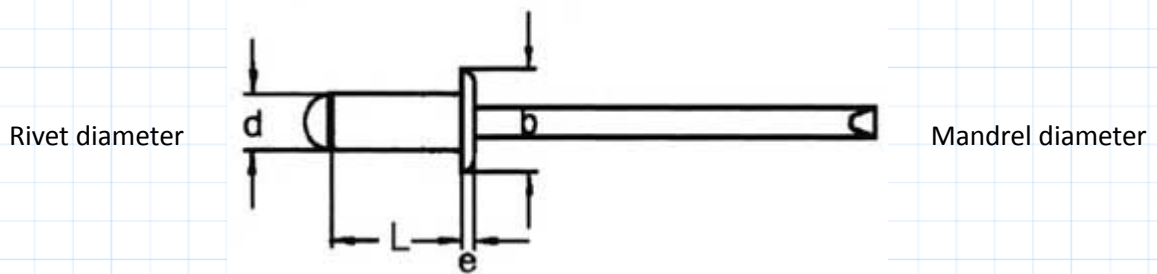

Rivet diameter

$$d_{rivet} := 4.8 \text{ mm}$$

Mandrel diameter

$$d_{mandrel} := 2.7 \text{ mm}$$

Rivet stress area

$$A_{\sigma} := \frac{\pi \cdot d_{rivet}^2}{4} - \frac{\pi \cdot d_{mandrel}^2}{4} \quad A_{\sigma} = 12.37 \text{ mm}^2$$

Tensile stress in rivet due to wind load

$$\sigma_{rivet} := \frac{F_{max_rear}}{A_{\sigma}} \quad \sigma_{rivet} = 71.256 \text{ MPa}$$

Tensile performance of rivets,

$$\sigma_{rivet_tensile} := 6000 \text{ N}$$

Minimum yield stress of rivets,

$$\sigma_{rivet_yield} := \frac{\sigma_{rivet_tensile}}{A_{\sigma}} = 485.044 \text{ MPa}$$

Partial material factor for steel, Ref 5

$$y_m := 1.05$$

Factored stress

$$\sigma_{rivet_factored} := \frac{\sigma_{rivet_yield}}{y_m} \quad \sigma_{rivet_factored} = 461.946 \text{ MPa}$$

Factor of safety based upon factored stress

$$fos_{rivet} := \frac{\sigma_{rivet_factored}}{\sigma_{rivet}} \quad fos_{rivet} = 6.483$$

3.3 Bending stress in the assembly.

When the assembly is mounted to its support pole and is subject to wind loads, a bending stress will be imparted into the assembly. Peak bending stress will be at R2 in the following figure. At R2 the geometry of the assembly also has the smallest second moment of area. The cross-sectional geometry at this point was used in all calculations. Note, only the geometry of the aluminium plate and the steel tube were considered in the calculation. All other materials such as the solar cells and coatings were ignored.

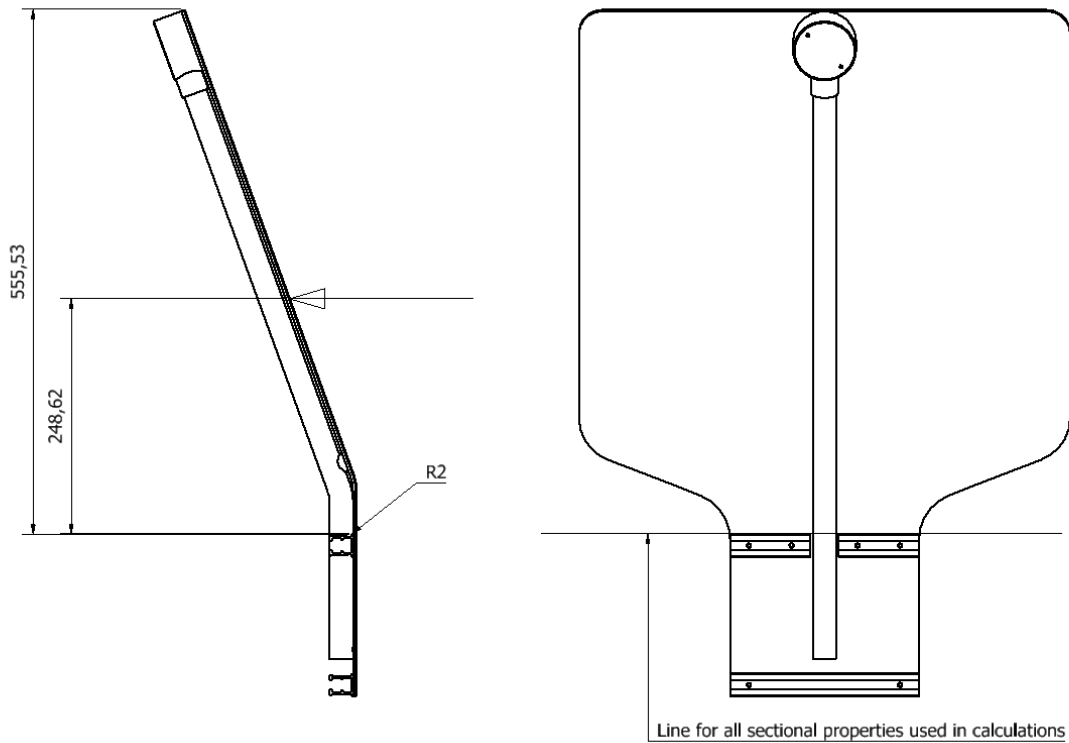

For calculation purposes the geometry of the assembly may be simplified to that in the following figure.

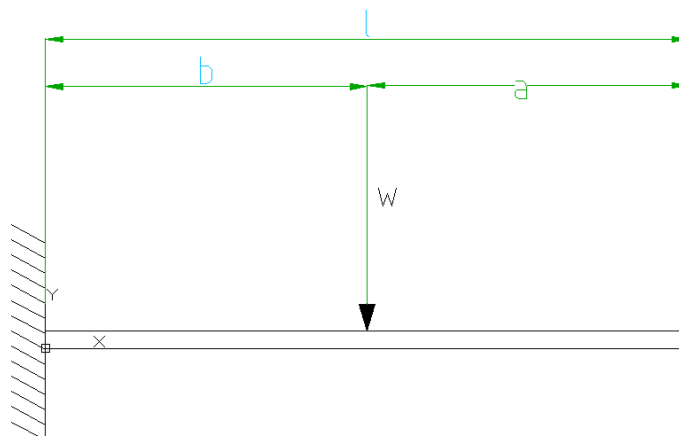

Design load case from wind loading

$$F_{wd1} = 1.345 \text{ kN}$$



Load application distance		$d_{F_{wd2}} := 248.62 \text{ mm}$
Moment applied about R2	$M_{R2} := F_{wd1} \cdot d_{F_{wd2}}$	$M_{R2} = 334.402 \text{ N} \cdot \text{m}$
Moment check using Ref		
Cantilever length, from CAD		$l_{canti} := 555.53 \text{ mm}$
Distance $b_{distance}$, from CAD		$b_{distance} := 248.62 \text{ mm}$
Length $a_{distance}$	$a_{distance} := l_{canti} - b_{distance}$	$a_{distance} = 306.91 \text{ mm}$
Moment at fixed end of cantilever	$M_{fixed} := F_{wd1} \cdot (l_{canti} - a_{distance})$	$M_{fixed} = 334.402 \text{ N} \cdot \text{m}$

From CAD, the second moment of area about the centroid of the cantilever is

```

----- REGIONS -----
Area:                1492.0238
Perimeter:          555.5398
Bounding box:       X: -100.0000  --  100.0000
                   Y:  -9.8701  --  18.1299
Centroid:           X:  0.0000
                   Y:  0.0000
Moments of inertia: X: 102738.9994
                   Y: 2031980.4696
Product of inertia: XY: 0.0000
Radii of gyration:  X:  8.2981
                   Y: 36.9039
Principal moments and X-Y directions about centroid:
                   I: 102738.9994 along [1.0000 0.0000]
                   J: 2031980.4696 along [0.0000 1.0000]

```

Thus I for the section is $I_{section} := 102738.9994 \text{ mm}^4$

Peak stresses will occur in the material furthest from the centroid. The material on which the wind load acts will be subject to a tensile stress. A compressive stress will be on the leeward side. The distance at which the maximum stress is applied is designated by y , and is shown in the following figure.

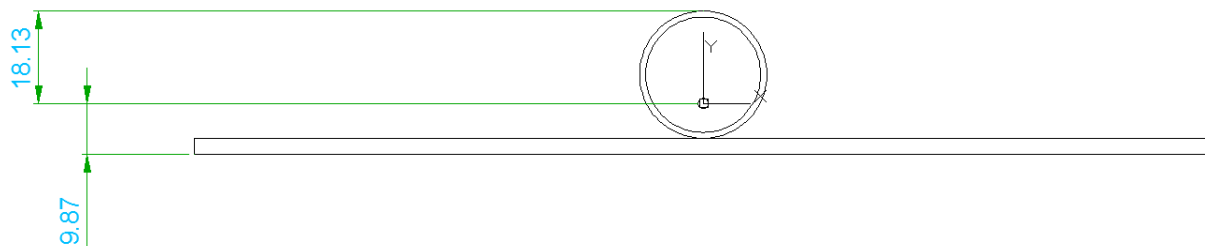

Thus for the aluminium plate y is: $y_{Al} := 9.87 \text{ mm}$



and for steel tube y is:

$$y_{Fe} := 18.13 \text{ mm}$$

Considering first moment of area for the Al plate

$$Z_{Al} := \frac{I_{section}}{y_{Al}}$$

$$Z_{Al} = 10409.22 \text{ mm}^3$$

Considering first moment of area for the Fe plate

$$Z_{Fe} := \frac{I_{section}}{y_{Fe}}$$

$$Z_{Fe} = 5666.795 \text{ mm}^3$$

Thus peak stress in the Al plate

$$\sigma_{Al} := \frac{F_{wd1} \cdot b_{distance}}{Z_{Al}}$$

$$\sigma_{Al} = 32.126 \text{ MPa}$$

and peak stress in the Fe plate

$$\sigma_{Fe} := \frac{F_{wd1} \cdot b_{distance}}{Z_{Fe}}$$

$$\sigma_{Fe} = 59.011 \text{ MPa}$$

3.3.1 Stress factors of safety in the assembly.

Minimum yield stress of Aluminium plate.
See CoC (actual value 174 Mpa)

$$\sigma_{Al_plate_yield} := 150 \text{ MPa}$$

Partial material factor for aluminium, Ref 5

$$y_m := 1.15$$

Factored stress

$$\sigma_{plate_factored} := \frac{\sigma_{Al_plate_yield}}{y_m}$$

$$\sigma_{plate_factored} = 130.435 \text{ MPa}$$

Factor of safety based upon factored stress

$$fos_{plate} := \frac{\sigma_{plate_factored}}{\sigma_{Al}}$$

$$fos_{plate} = 4.06$$

Minimum yield stress of Steel tube.
(http://www.efunda.com/materials/alloys/alloy_home/steels_properties.cfm worst case)

$$\sigma_{Fe_tube_yield} := 186 \text{ MPa}$$

Partial material factor for steel, Ref 5

$$y_m := 1.05$$

Factored stress

$$\sigma_{tube_factored} := \frac{\sigma_{Fe_tube_yield}}{y_m}$$

$$\sigma_{tube_factored} = 177.143 \text{ MPa}$$

Factor of safety based upon factored stress

$$fos_{tube} := \frac{\sigma_{tube_factored}}{\sigma_{Fe}}$$

$$fos_{tube} = 3.002$$

