



Traffic Management Products
Unit 6 Britannia Park, Trident Drive,
Wednesbury, West Mids. WS10 7XB

0208 744 8201
www.trafficmanagementproducts.co.uk

Tactile

Paving communication

Quick to install and out-performs concrete

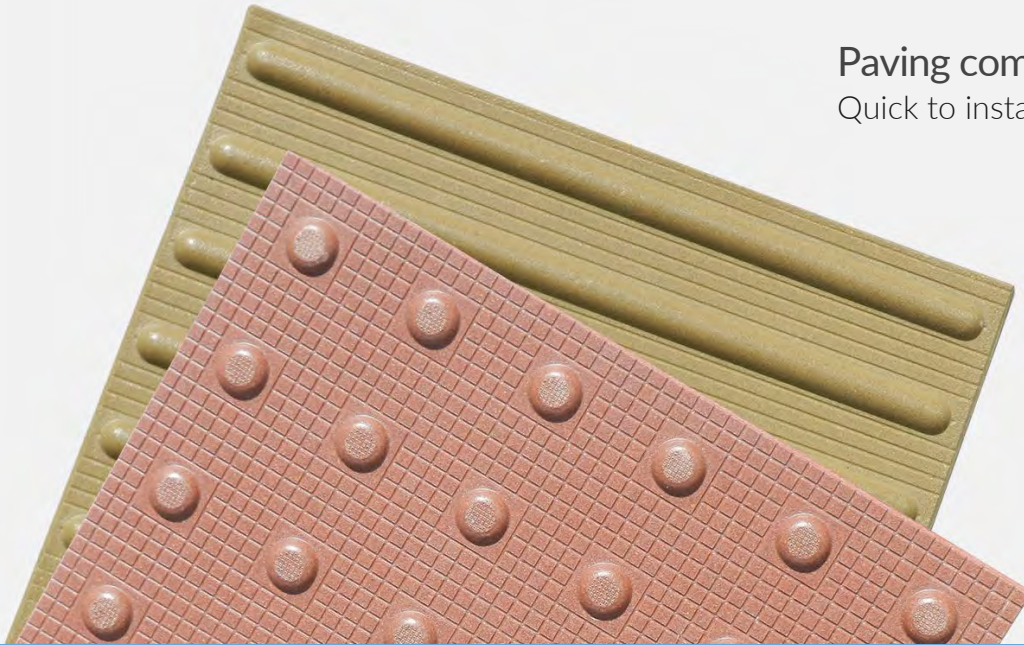

Robust lightweight tiles, the ideal alternative to traditional concrete slabs

Coming in two different variants - Blister and Corduroy, Tactile paving will convey different messages underfoot to visually impaired people of upcoming hazards.

- Quick and easy to install
- Flexible and lightweight
- Blister or corduroy profiles
- Each tile emits 98% less carbon emissions than the concrete equivalent
- Guarantee of 10 years
- Slip resistant
- Crack and wear resistant
- Conforms to DDA and DETR guidelines
- No excavation needed



Flexible surface-mounted tactile paving

The lightweight paving can be installed on any surface, with built in flexibility for all weathers. Unlike concrete paving, Tactile tiles can be surface-mounted onto an adhesive made of the same material allowing them to cross-link into the adhesive forming a weather-resistant impenetrable seal. The resin/aggregate tiles last 6 times longer than traditional concrete pavers.

The product is Micro Abrasion certified by Newcastle University and it has passed the skid and wear test for Network Rail.

Specifications

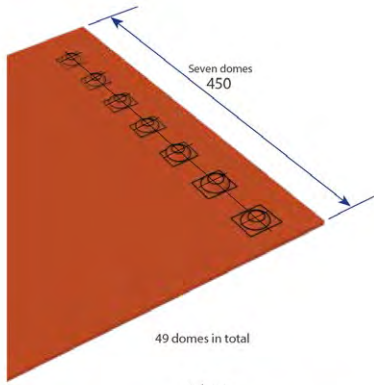

Blister - rows of flat-topped 5mm high blisters

The tactile Blister paving is essential to the safety of visually impaired people navigating our busy streets. This profile underfoot gives warning to the change of a footpath that meets a road, where there are no kerbs to differentiate the two.

The Buff coloured variant is used for where there are controlled crossing points, such as zebra, pelican and puffin crossings. The red variant is put in place where there are uncontrolled crossing points such as side road crossings, kerb to kerb flat road humps and busy cross overs.

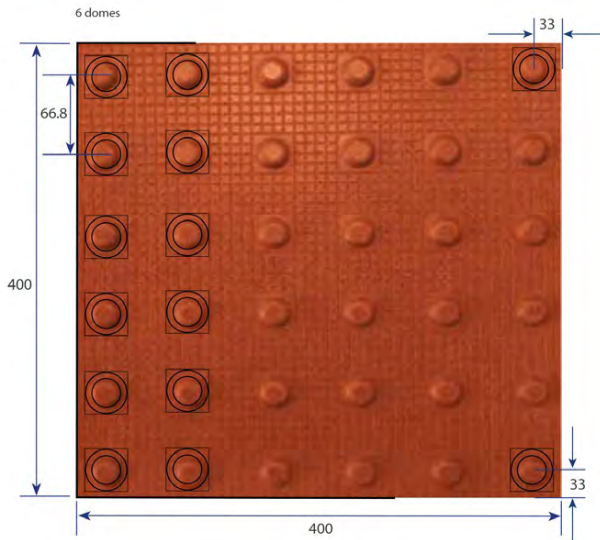

Material	Flexible Polyurethane
Colour	Red or Buff
Tile size	400x400mm or 450x450mm
Weight	0.94kg (per tile)
Profile	Blister
Tile coverage per box of 10 tiles	400x400mm covers 1.6 squared meters or 4 linear meters 450x450mm covers 2 squared meters or 4.5 linear meters
Installation Options	PU Resin
DDA 2005 /DETR	Complies to guidelines

Note: The exact colour/tone may vary batch to batch.

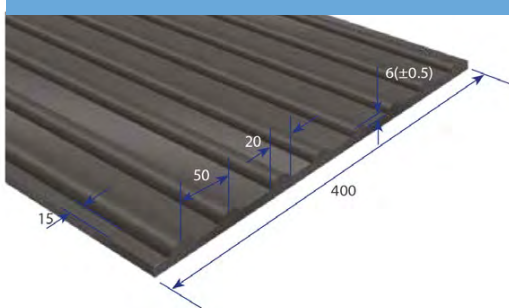

Corduroy - rows of 6mm high rounded bars

The Tactile Corduroy paving is also very important to pedestrians negotiating our footpaths. The profile differs from the Blister profile to convey a different message: 'hazard, proceed with caution'.

The Corduroy highlights the presence of specific hazards such as steps, level crossings or the approach to on-street rapid transit platforms (LRT). Comprising of rounded bars running transversely across the direction of the pedestrians travel.

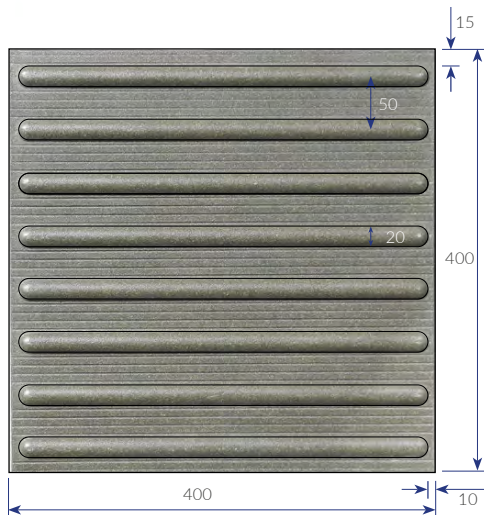
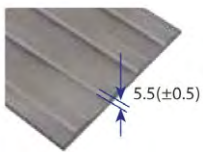

Material	Flexible Polyurethane
Colour	Charcoal or Buff
Tile size	400x400mm
Weight	0.94kg (per tile)
Profile	Corduroy
Tile coverage per box of 10 tiles	400x400mm covers 1.6 squared meters or 4 linear meters
Installation Options	PU Resin
DDA 2005 /DETR	Complies to guidelines

Note: The exact colour/tone may vary batch to batch.